

DELUXE CAREFREE AWNINGS

OWNER'S MANUAL

I Installation Instructions

IV Exploded Parts Drawing

VII Carefree Product Guide

II Operating Instructions

V Troubleshooting Guide

III Maintenance **VI** Warranty Information

**WARRANTY
REGISTRATION
ENCLOSED
DEALER SIGNATURE REQUIRED**



Carefree of Colorado
Uncompromising Quality.
AUTHORIZED DEALER

Carefree of Colorado, A Scott Fetzer Company,
2145 W. 6th Ave., Broomfield, CO 80020 • (303) 469-3324

Form No. 052650 Rev. 12-86

READ ENTIRE INSTRUCTIONS BEFORE STARTING
INSTALLATION. FOLLOW ALL CAUTIONS,
WARNINGS AND NOTES TO PREVENT INJURY OR
DAMAGE TO AWNING OR VEHICLE.

SECTION I INSTALLATION INSTRUCTIONS

Installation Sequence:

1. Installation Preparation	Page 3
2. Door Roller Installation	Page 3
3. Awning Roller Preparation	Page 3
4. Roller and Spring Assembly	Page 3
5. Awning Installation	Page 4
6. Bottom Bracket Installation	Page 4
7. Top Bracket Installation	Page 4
8. Awning Height Adjustment	Page 4
9. Stop Bolt Installation	Page 5
10. Securing Canopy	Page 5
11. Locking Pin Installation	Page 5
12. Pull Strap Attachment	Page 5

TOOLS REQUIRED:

- Electric Drill
- Drill Bits:
3/32", 1/8", 9/32" and 5/16"
- Extension Cord
- Step Ladder
- Sockets or Wrenches: 3/8", 7/16" and
5/16"
- Ratchet or Speed Handle
- Screwdrivers: Flat, Square, and Phillips
Head
- 4" C-Clamp
- Caulking Gun
- Tape Measure

SUPPLIES REQUIRED:

- Putty Tape
- Masking Tape
- Non-hardening Caulking Compound
- Silicone Spray Lubricant

INSTRUCTIONS FOR TRAILERS AND MOTOR HOMES WITH STRAIGHT SIDES.
FOR CURVED SIDED VEHICLES, USE THESE INSTRUCTIONS ALONG WITH SPECIAL
INSTRUCTION AMENDMENT SHEETS SUPPLIED WITH CURVED HARDWARE.

1. Installation Preparation

- Check vehicle to see if awning rail is installed. If not, mount one with rivets or screws. Seal back of rail with putty tape.
- Decide where arms will fit and not interfere with lights, vents, mirrors, etc. Must be in even feet between center of brackets.
- Cover any sharp projections with padding (rag or paper) and masking tape to avoid scratching holes in awning when threading into awning rail channel.
- Straighten and smooth awning rail. Use a screwdriver to spread one end slightly to allow easy insertion. Silicone spray will aid insertion.

IF TRAILER HAS NO AWNING RAIL, MOUNT ONE INTO THE ROOF LINE STRUCTURE WITH RIVETS OR SCREWS

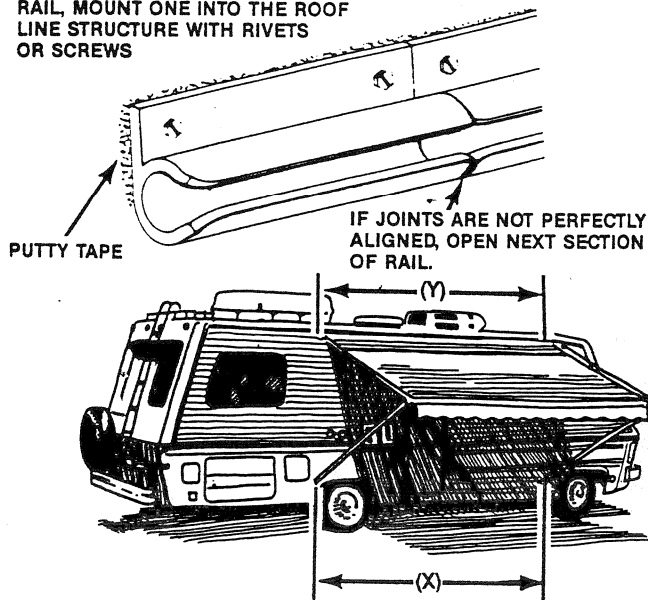

CAUTION: Awnings must be mounted into the framework of the vehicle. Fiberglass or sheet metal siding is not strong enough to support the weight of the awning.

2. Door Roller Installation

NOTE: Door roller is to be installed before installing awning.

- To avoid damage to awning fabric, mount door roller on outside door using two #12 x 1/2" slotted hex head screws.
- Mount white disc on screen door using #6 x 1/2" slotted pan head screws. Rounding off the corners of doors is a good precaution.

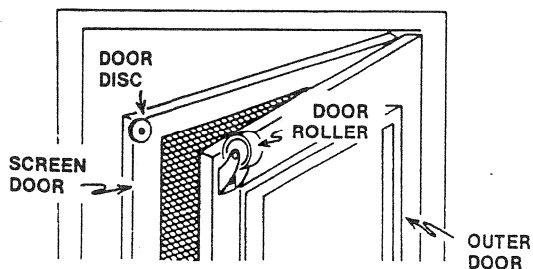

3. Awning Roller Preparation

- Remove awning from shipping tube and plastic bag. Two-slotted roller tubes will fit Deluxe, Classic and Standard Carefree Arms. **Do not remove tape from around roller.**
- If roller tube has standard style spring assemblies with plastic end caps, remove two end cap screws and remove spring assembly from roller. The roller tube may be out of round making it difficult to fit the end cap. Use a 4" C-clamp near end of roller tube to force tube round. Burrs around screw holes in roller tube need to be removed.

Cut Polyrod in canopy and valance slots so that it is flush with end of roller tube.

4. Roller and Spring Assembly

- Remove awning arms from box and determine front and back assemblies. Springs are wrapped in cardboard and taped to arms; front spring assembly to front arm and back spring assembly to back arm. Tag on spring assemblies indicates front or back, yellow is front, red is back. Do not remove power spring safety clamp until Step 10.

Place arm on level surface so that trunnion (grooved rod through roller end cap center) POINTS UP (see illustration). Turn spring assembly until trunnion screw point or key way will slide into groove in trunnion. Slide spring assembly down over trunnion until it contacts the push nut. Allow spring assembly to sit by its own weights on push nut while tightening screw, using a 5/16" wrench or socket until screw head bottoms out. **DO NOT PUSH SPRING ASSEMBLY DOWN ONTO PUSH NUT.** Cut end off spring bag to expose spider. Repeat process with other arm.

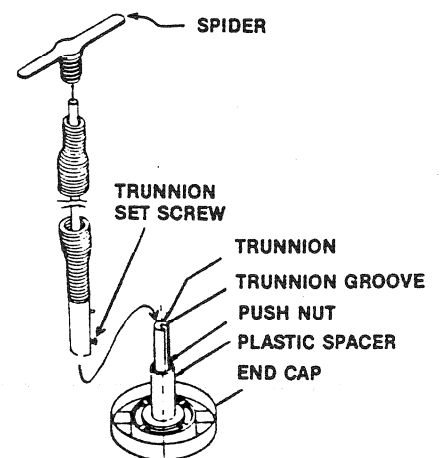

- Align slot in spring end cap with roller tube valance slot. Valance slot is marked with black on end of tube. Insert spring into roller.
- Using two holes in spring end cap as guides, drill two 1/8" holes in the roller tube.
- Secure spring assembly to roller tube using #8 x 3/8" Phillips oval head screws.
- Repeat above with other spring assembly.

5. Awning Installation

- Move to end of vehicle from which awning is to be installed.
- Wind awning the required number of turns towards vehicle. See illustration.
- Unlock operating handles and extend arms vertically until roller tube is level with awning rail. Lock operating handles and rest awning on ground.

Awning Length	Number of turns
10'-11'	5
12'-14'	6
15'-17'	7
18'-20'	8
21'	9

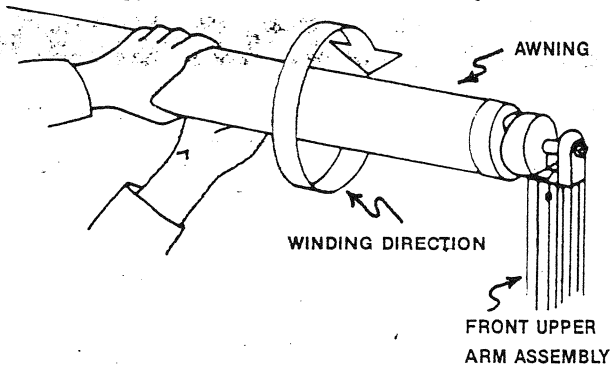

- Standing on a ladder, slide awning into awning rail. With a helper on the ground, continue feeding the awning into the rail while the helper walks the arm forward. Helper should move between arms as needed.

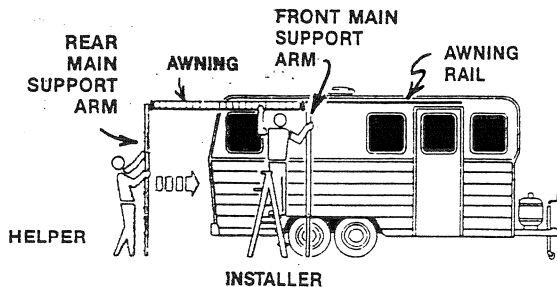

6. Bottom Bracket Installation

- Measure and center bottom bracket so arms are perpendicular to ground.
- If bottom bracket is to be placed on flat surface, bottom bracket shim should be used as shown. If mounting over trim molding, bottom bracket shim is not required.

NOTE: Installation of the bottom bracket on travel trailers having a floor line structure at bottom of trailer sidewall may require the use of optional bottom bracket adaptor. This will allow bracket to be centered on the floor line and provide additional support for lower edge of bracket.

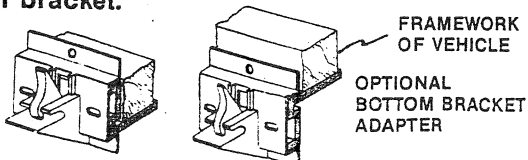

Bottom Bracket Installation (Cont.)

- Mount bottom bracket into floor line structure using two #14 x 2-1/2" screws per bracket. Insure bracket is level to permit easy insertion of carport foot.

CAUTION: Trim molding is usually aligned with floor members, but check to be sure. Screws must be into frame of vehicle.

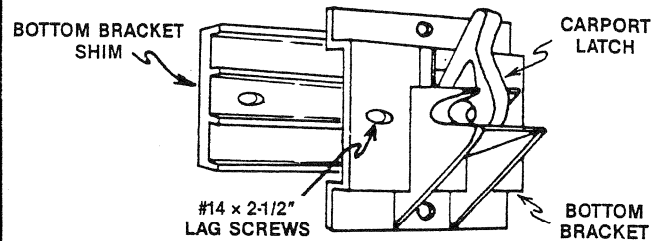

- Insert carport foot into bottom bracket.

NOTE: A bottom bracket stand-off is available to position the awning arms further away from the vehicle.

7. Top Bracket Installation

- Position top brackets over awning rail so braces nest into arm channels. However top bracket does not need to be over awning rail. Be sure bracket is secure by screwing into roof line structure. Secure to vehicle using two #14 x 2-1/2" lag screws.

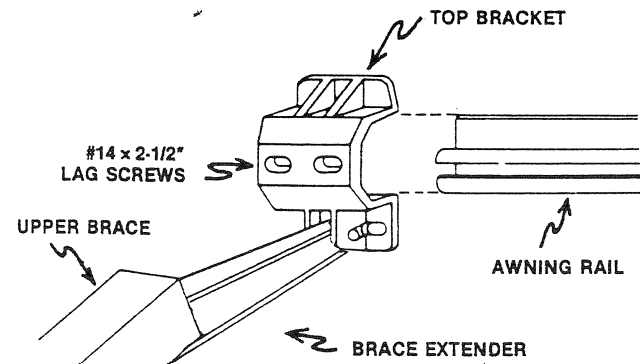

8. Awning Height Preparation

Position the Awning so that there is a gap between end plug and top of upper brace. Position of roller can vary per illustration. Handles should be in the "IN" position with the spring loaded pin seated in a hole of the lower arm channel that sets the proper height of the roller.

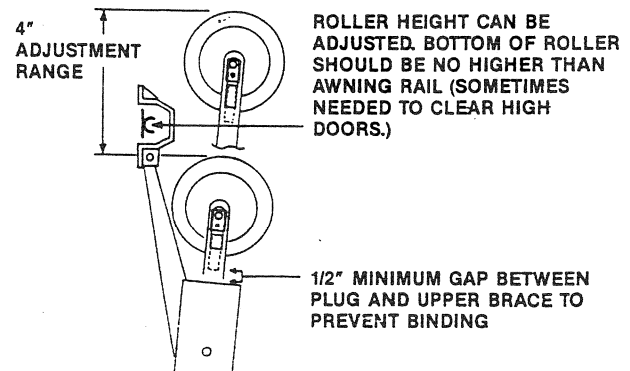

9. Stop Bolt Installation

To allow awning to extend and retract correctly, it is necessary to install a stop bolt.

- Drill a $9/32$ " hole in lower arm channel just below upper arm section. (See arm label.)

NOTE: Hole should be drilled as close as possible to bottom of upper arm channel. Handle locking pin does not have to be in hole after stop bolt is installed.

- Place $1/4$ "— $20 \times 3/8$ " truss head bolt with $1/4$ " star washer through hole in arm channel from the rear. From front, secure bolt with $1/4$ "— 20 cap nut.

- Remove stop bolt label.

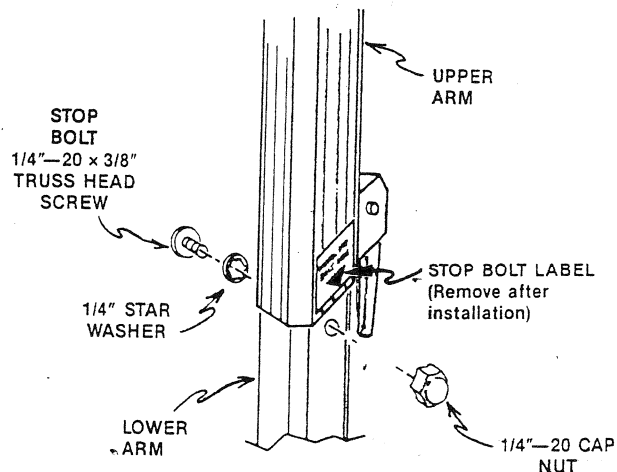

10. Securing Canopy

- Raise handle to out position and extend awning. Do not lower handles.

- Remove power spring safety clamp by removing oval head screw. Replace screw to secure end cap. Spring tension is now on awning.

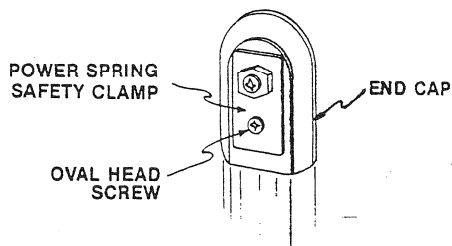

- Extend awning several times (see Operating Instructions) to be sure that it rolls smoothly and canopy rolls straight. It may be necessary to slide canopy in awning rail toward one end to allow canopy to roll straight.

- To prevent awning from moving in awning rail, drill two $3/32$ " holes through awning rail, polyrod and canopy approximately 2" from each end of canopy. Put a $\#6 \times 3/8$ " phillips pan head screw in each hole.

NOTE FOR ACRYLIC CANOPY AWNINGS:

Acrylic canopy awnings with Alumiguard™ slatted weatherguard must be secured to awning rail by installing the $\#6 \times 3/8$ " screws **OUTSIDE** of the Alumiguard™—**NOT THROUGH IT!**

Securing Canopy (Cont.)

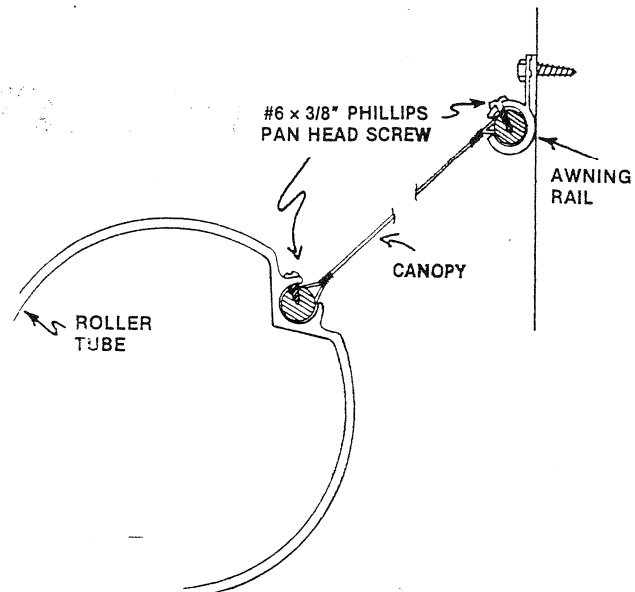

- Drill two $3/32$ " holes into roller tube canopy slot and secure canopy to roller tube with two $\#6 \times 3/8$ " long phillips pan head screws. Put screw between vertical stitches. (See illustration)

NOTE: Screw in roller tube must be below surface of roller to prevent damage to canopy.

11. Locking Pin Installation

- Insure brace hook is seated against carport latch of bottom bracket and handle is in the "IN" position with awning rolled up.

- Squeeze the arm channels together and drill a $5/16$ " hole through all arm channels. Locate this hole position using the prepunched holes in the upper arm channel. Drill half-way through from each side of the arm.

- Insert arm locking pin.

- Repeat on other arm.

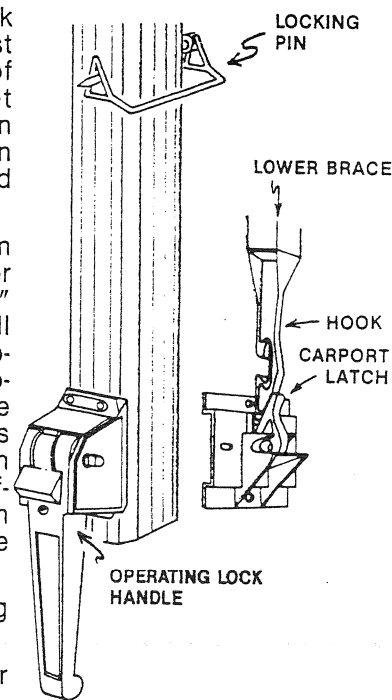

12. Pull Strap Attachment

- Extend awning. (See Operating Instructions)
- Stretch pull strap under canopy along roller tube.
- Place self-adhesive Velcro button on roller tube to correspond with Velcro on pull strap loop.

SECTION II OPERATING INSTRUCTIONS

1. To Extend Awning:

- Remove arm locking pins and stow in lower arm. Loosen black locking knobs.
- Depress thumb latch and raise both handles to "OUT" position.
- Hook loop of center pull strap with pole and draw the awning away from vehicle to extend awning.
- Remove braces from storage position and place hook over rod on top of spring assembly. Push brace outward and tighten locking knob.
- Grasp handle and raise front of awning high enough to clear open door. Depress handle thumb latch and place handle in "IN" position.
- Store pull strap along roller tube and secure on Velcro button.

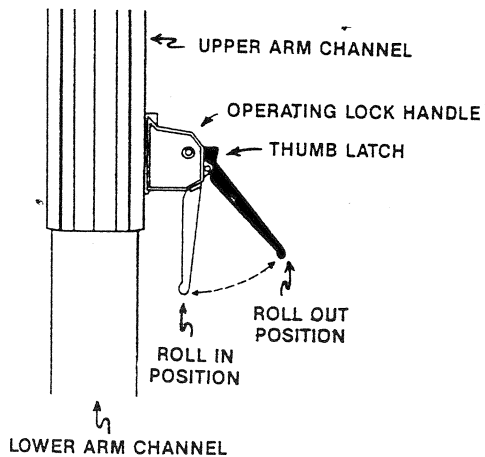

2. To Retract Awning

Reverse steps in "1" above.

CAUTION: When retracting awning, handles should be in the "IN" position and remain in the "IN" position for travel to prevent damage to awning, vehicle or personal injury.

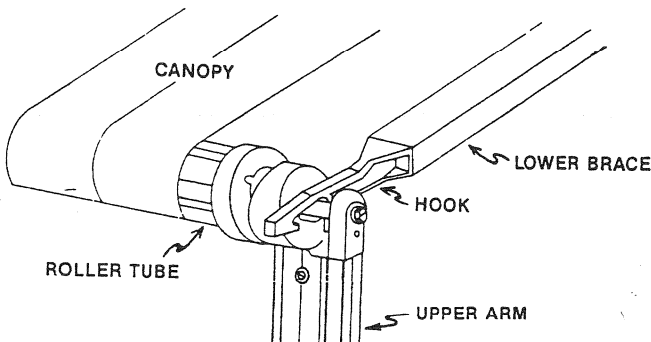

NOTE: "ROLL OUT" position handle is a positive catch. Raise handle slightly in order to release thumb latch from "OUT" position.

3. Using Carport Feature

- To place awning in carport position, extend awning as described in #1A. Insure BOTH handles are in the "IN" position.
 - Grasp lower arm section with one hand and release carport latch on bottom bracket with free hand.
 - Separate carport foot from bottom bracket and swing arm assembly away from vehicle until perpendicular to ground.
 - Drive stakes through holes in carport foot.
- CAUTION:** Stakes will not prevent awning from moving in high winds.
- Adjust arms to place awning at proper height.
 - Reverse steps #3A-E above when taking awning out of carport position.

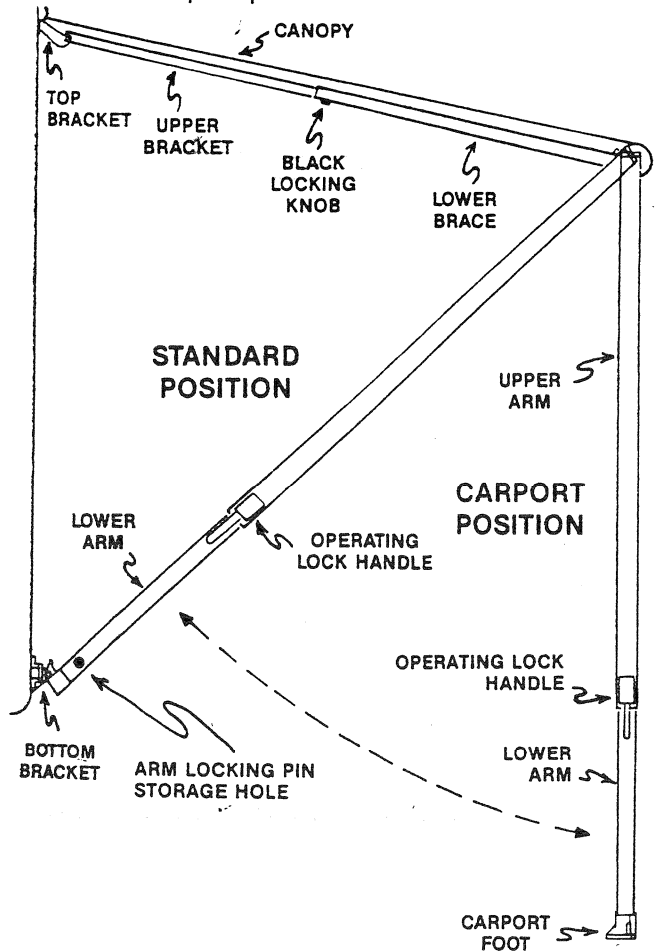

CAUTION: When placing awning in carport position or taking awning out of carport position, BOTH handles should be in the "IN" position or damage will result to spring assemblies.

4. Partial Extension Position

Extend awning as described in #1A. Set brace length to desired extension between 4 and 8 feet. To achieve taut canopy, place both handles to "IN" position.

5. Awning Use in the Rain

If rain or wind are expected, roll up the awning and secure it for travel. (See Operating Instructions, page 6, #2.)

CAUTION: The effects of wind and rain on an awning are unpredictable. Severe damage to the awning and the vehicle may result and cannot be covered by warranty.

SECTION III MAINTENANCE

1. Care of the Deluxe Awning

A. Vinyl Canopy

Mildew will not form on the awning material itself, but may form on the dust allowed to accumulate on the canopy. A quality vinyl cleaner such as Awning Magic™ will keep your vinyl awning looking like new. Follow instructions on the container.

B. Acrylic Canopy with Alumiguard™

A warm soapy solution should be used to clean the acrylic canopy. A stiff brush and a solution of ½ cup detergent in a gallon of warm water will help in removing stubborn marks. Use plenty of clean water to completely rinse out all soapy water.

C. Metal

Metal surfaces should be cleaned with warm soapy solution and thoroughly rinsed.

NOTE: Allow canopies to dry completely before rolling awning up.

2. Periodic Maintenance

Like any other part of his RV, an owner should periodically inspect his awning. The following items should be checked:

- A. All lag screws in brackets are tight.
- B. Apply oil to the threaded shafts of all black locking knobs and handles. A light household oil or spray lubricant should be used to prevent corrosion.
- C. Check all arm pivot points for enlargement of holes or broken rivets.
- D. Check end caps for cracking, splitting.
- E. Check that awning rail is tight against coach and all screws are tight.

CAUTION: Do not use caustic cleaners, mildew removers or metal cleaners on fabric as they can destroy colors and will not be covered by warranty.

SECTION IV EXPLODED PARTS

DELUXE CAREFREE AWNING PARTS LIST

Exploded View Designation	Description	Part Number	Quantity Per Pak
AA	Front Head Assembly Complete w/two attaching screws Black	169043	1
A	Front Spring Assy	169045	1
BB	Rear Head Assembly Complete w/two attaching screws Black	169044	1
B	Rear Spring Assy	169046	1
C	#1 Upper Arm Section w/Handle Assembly		
	63" Front	Black 169023	1
	63" Rear	Black 169024	1
	#1 Arm Only		
	63" Front	071310	1
	63" Rear	071311	1

D	#2 Lower Arm Section w/Carport Foot		
	56" Front	Black 169025	1
	56" Rear	169026	1
	#2 Arm Only		
	56" Front	071320	1
	56" Rear	071321	1
E	#3 Lower Brace w/Hook—44"	Black 169027	1
	44" #3 Brace Only	071330	1
F	#4 Upper Brace w/Top Assembly Bracket—44"		
		Black 169028	1
	50" #4 Brace w/Rivnut Only	169035	1

G. Carefree Canopy & Valance w/Polyrod and Gray Weatherguard

SIZE	LENGTH		PART NUMBER	QUANTITY PER PAK	
8'	88"		1280*	1	
9'	100"		1290*	1	
10'	112"		1210*	1	
11'	124"		1211*	1	
12'	136"	+ 1912*	°201200	1212*	1
13'	148"			1213*	1
14'	160"	+ 1914*	°201400	1314*	1
15'	172"			1215*	1
16'	184"	+ 1916*	°201600	1216*	1
17'	196"			1217*	1
18'	208"	+ 1918*	°201800	1218*	1
19'	220"			1219*	1
20'	232"	+ 1920*	°202000	1220*	1
21'	244"	+ 1921*	°202100	1221*	1

* Add digits for color designation

° Part number for Carefree Acrylic Canopy only

° Part number for Alumiguard™ individual replacement slats

01 — Gold/White stripe	16 — Orange/Cream stripe
02 — Olive/White stripe	17 — Burnt Orange/Cream stripe
03 — Blue/White stripe	18 — Tequila Sunrise
04 — Red/White stripe	21 — Blue Hawaii Sunrise
05 — Brown/White stripe	22 — Kahlua Sunrise
06 — Olympiad	23 — Burgundy Sunrise
07 — Orange/White stripe	24 — Mint Julep
08 — Brown/Tan stripe	25 — Wine Sunrise
09 — Burnt Orange/White stripe	31 — Brown Sunbrella
10 — Black/White stripe	32 — Blue Sunbrella
11 — Brown Seville	33 — Oyster/Red Sunbrella
12 — Tan Seville	41 — Coffee Sunrise
13 — Cinnamon/Cream stripe	42 — Blueberry Sunrise
14 — Blueberry/Cream stripe	43 — Tangerine Sunrise
15 — Raspberry/Cream stripe	44 — Plum Sunrise

H. Carefree Awning Cylinder Only. Less Canopy & Springs. May be cut to size as needed (typ. 5" less than stated size, i.e., 18' = 17'7")

8'	Cylinder Only	148000	1
9'	Cylinder Only	149000	1
10'	Cylinder Only	141000	1
11'	Cylinder Only	141100	1
12'	Cylinder Only	141200	1
13'	Cylinder Only	141300	1
14'	Cylinder Only	141400	1
15'	Cylinder Only	141500	1
16'	Cylinder Only	141600	1
17'	Cylinder Only	141700	1
18'	Cylinder Only	141800	1
19'	Cylinder Only	141900	1
20'	Cylinder Only	142000	1
21'	Cylinder Only	142100	1

I	Brace Hook w/Rivets	Black	169029	1
J	Handle Assembly w/Rivets & Cable	Black	169030	1
	Cable Only		169019	
K	Carport Foot w/Rivets	Black	169031	1
L	Bottom Bracket Assembly	Black	011301WBLK	1
M	Bottom Bracket Shim		071300	1
N	Carport Stakes		905004	1
O	Stop Bolt Assembly Acorn Nut, Lock Washer & Bolt		PAK011131	1
P	Locking Pins		905003	2
Q	Black Locking Knob		905001	4
R	Plug Housing Cover w/Screw	Black	169038	1
W	Top Bracket w/Extension	Black	169040	1

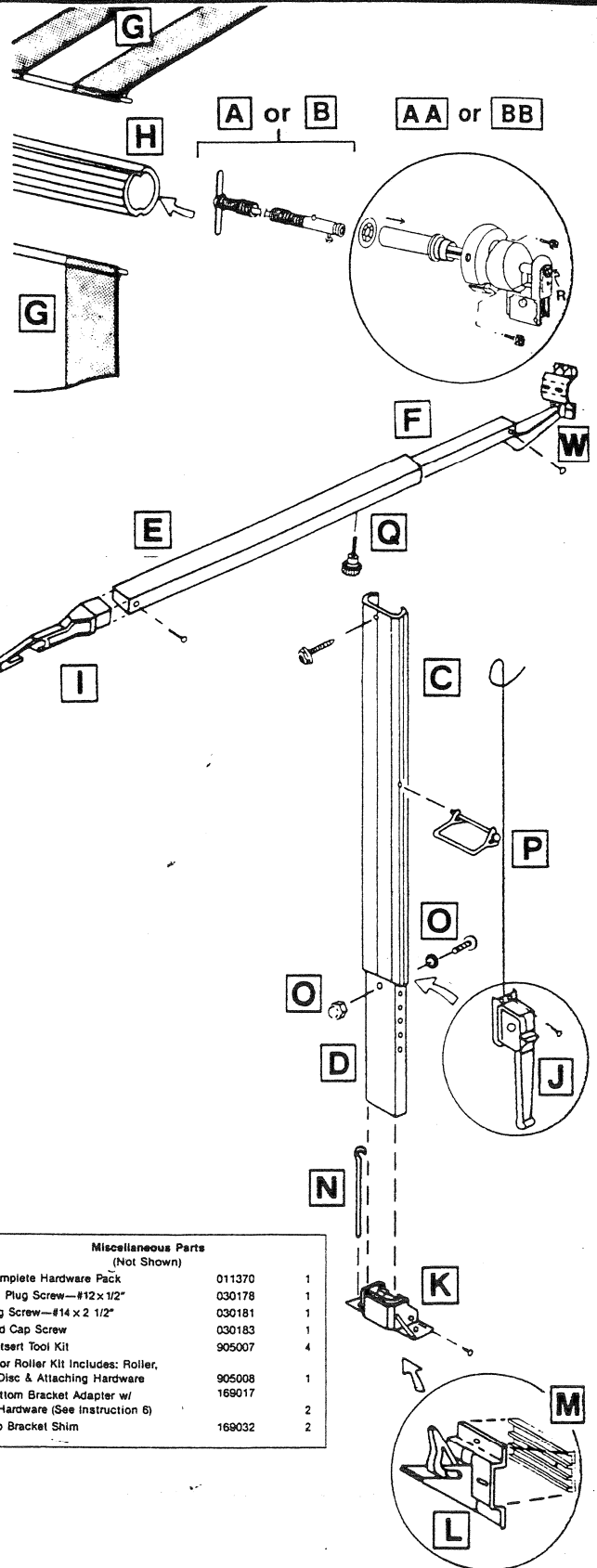

Miscellaneous Parts (Not Shown)	
Complete Hardware Pack	011370 1
AA Plug Screw—#12x 1/2"	030178 1
Lag Screw—#14 x 2 1/2"	030181 1
End Cap Screw	030183 1
Nutsert Tool Kit	905007 4
Door Roller Kit Includes: Roller, Disc & Attaching Hardware	905008 1
Bottom Bracket Adapter w/ Hardware (See Instruction 6)	169017 2
Top Bracket Shim	169032 2

NOTE: Use only genuine Carefree of Colorado parts and components for replacement or improper operation may result, warranty may not be honored and product damage could result.

Parts are available from Carefree of Colorado dealers in every state.

Call the factory customer service department if you require assistance (303) 469-3324.

SECTION V TROUBLESHOOTING GUIDE

Symptom	Probable Cause	Solution
Awning won't fully extend.	Spring over wound.	Take off excess turns—see instructions (page 4) for correct number of turns.
Awning won't roll in.	Not enough tension. Handles in "OUT" position. Power spring safety clamp still installed. Outlock spring won't release.	Add tension to each spring in correct direction. Place handles in "DOWN" position. Remove—see instructions (page 5) Lightly spray outlock and travel lock springs with silicone. Place handle to "IN" position. Check to see if broken.
Spring won't hold tension.	Springs reversed in roll bar. Head assemblies reversed.	Check to see that the spring with yellow tag is in front and spring with red tag is in back. See instructions (page 3). Head assemblies have the same color tag.
Carport foot won't go into bottom bracket.	Bottom bracket not level. Bottom bracket catch jammed or broken.	Check bottom bracket level. Check for proper operation.
Awning won't roll out.	End plug resting on top of braces (both sides). Handles in "IN" position. Quick release pin in place. Brake cable.	Raise arms to next highest hole—reposition stop bolt—See instruction (page 4 & 5). Place handles in "OUT" position. Remove. Check for correct adjustment.
Handle hard to operate.	Parts binding. Brake cable.	Lubricate (silicone)—see maintenance instructions. Check for correct adjustment.
Spring housing hits braces when rolling up.	Stop bolt set too low.	Raise #1 arm channel to a position that spring housing plug clears top brace, and reposition stop bolt hole—see instructions (page 4 & 5).

CAUTION: To prevent damage or personal injury, repairs and adjustments to the awning spring and clutch assemblies should be made by factory authorized personnel only. Call the Carefree Customer Service Dept. for your nearest Authorized Dealer.